

DSP5065 DSP5165 DSP5265

PA Speaker



Description

This series of products is a multi-functional loudspeaker, available in wall-mounted, pendant, and floor types. This series of products can provide high-quality voice and music reproduction functions, and relatively long sound transmission distance. It is suitable for conference rooms, shopping malls, exhibition halls and other indoor and outdoor occasions.

Features

- Suitable for public address and background music playback.
- With clear and bright sound, bringing quality sound experience.
- Using high-quality PP material for drum paper of the speaker unit, rubber edge moisture-proof treatment, and silk dome tweeter for good sound quality and timber performance.
- Simple in appearance and shape, using fine round hole diffusion design for the mesh, beautiful and durable, so that the speaker can be perfectly integrated into any occasion.
- Using high-strength ABS material for the shell, sturdy and durable.
- Equipped with mounting bracket, easy to install.

Specifications

Model	DSP5065/DSP5165/DSP5265
Speaker Unit	6.5"×1+1"×1
Rated Power (RMS)	50W
Working Voltage	70V/100V
Sensitivity (1m, 1W)	88dB±2dB
MAX. SPL. (1m)	105dB±2dB
Frequency Response	90Hz~20kHz
Dimensions (H×W×D)	∅225×305mm
Weight	3.4kg

Product Information

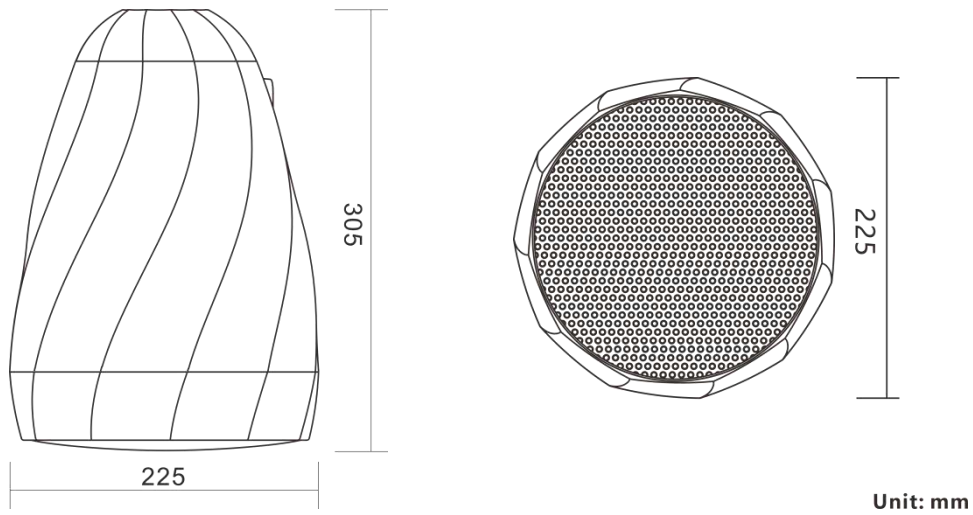

Technical Parameters

Frequency Response
(dB SPL, 1W, 1m)

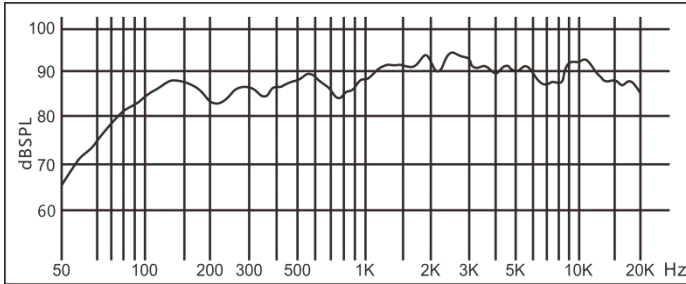

Distortion

(THD < 5% 1W, 1m, 100Hz-10kHz)

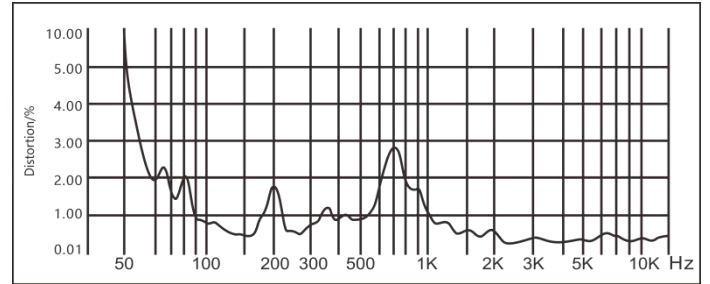

Directivity

